

SKY CLIMBER®

1501 Rock Mountain Blvd.
Stone Mountain, GA 30083

Tel: 770/939-7705

800/255-4629

Fax: 770/493-7392

Boomsesteenweg 14, 2630

Aartselaar Belgium

Tel: 32 3 887 81 20

Fax: 32 3 887 09 94



www.skyclimber.com

Safety is Important.

DAILY OR BEFORE START OF EACH SHIFT CHECKLIST

DO NOT use Sky Climber Hoists, Sky Locks or equipment which is damaged or worn beyond normal tolerances.

1. Instructions are kept with the unit at all times. (Additional copies are available. Contact Sky Climber.)
2. All Warning / Rating Labels are in place, legible and have been read.
3. Hoist Drain Holes on Bottom Are Open. Check Fasteners.
4. Suspended Platform Hoist is connected to proper power source.
5. Minimum of 3 J-clamps are used and are tight.
6. Cornice hook, parapet clamps or outriggers are secured and tied back. Chocks or similar devices are securely in place. Tie backs are tight and straight back.
7. Counterweights are nonflowable type, secure, and right amount.
8. Roof rigging load is spread using 3/4" plywood. Hard wood is used for Load Spreader with Parapet.
9. Wire rope inspected and is not kinked, bird caged or otherwise damaged.
10. The wire rope bitter end is looped and secured with a J-clamp.
11. Sky Lock, Hoist Load, Controlled Descent, Emergency Stop Tests performed and acceptable.

Sky Climber Products are Serviced in Your Area By:

SKY CLIMBER®

TOTAL ACCESS SOLUTIONS • EXCELLENCE IN RELATIONSHIPS

OPERATOR'S INSTRUCTION MANUAL COMPACT 1250 HOIST AIR AND ELECTRIC POWER

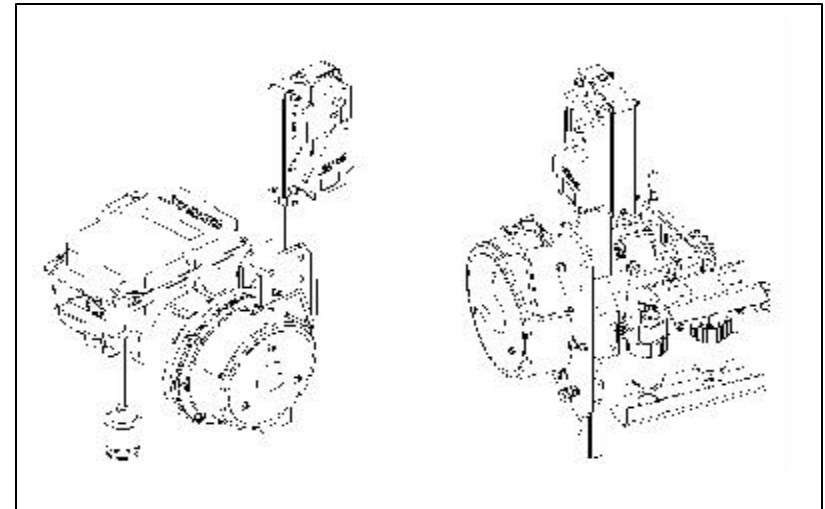

TO EMPLOYER AND/OR RENTAL AGENCY

It is imperative that this Manual be given to the Operator of Sky Climber equipment and that they read, fully understand, and follow all instructions contained herein.



WARNING:

Any use of this equipment other than in strict accordance with these instructions shall be at the Operator's risk and may result in serious injury to themselves or others.

REMEMBER SAFETY IS THE RESPONSIBILITY OF BOTH YOU AND THE OPERATOR.

STEEL WIRE ROPE REQUIREMENTS

Recommended Wire Rope, Compact 1250

Sky Climber has found that the 5/16", (8.4 mm) 5 strand wire rope to be the most effective for trouble free operation. Please use only that rope which is recommended by the manufacturer.

Product:
5/16" (8.4mm) 5 x 26 WS, PFC, G, XIP, RRL, Preformed, break strength at 11,585 lbs.

Compliance:
Use only the specified wire rope in the Compact 1250 hoist. If further information is needed, please contact Sky Climber at 770/939-7705 or 800/255-4629. All wire rope used must conform to Federal Specifications, RR-W-410P Type 1, General Purpose, Class 2. The supplier should provide a Certification of Breaking Strength proving a minimum strength. This rope is resistant to abrasion and crushing with medium fatigue resistance.

WS	Warrington Seal	PFC	Polypropylene Fiber Core
G	Galvanized	XIP	Extra Improved Plow
RRL	Regular Right Lay Steel		

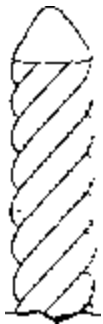

TIPPING AND BRAISING

Braze a wire rope tip by applying braze to approximately 1/2 inch of tip (do not exceed 3/4 inch) and let it flow to all of the individual wires. Let rope AIR COOL. Air cooling is very important. Then grind the tip to a taper, but not a point. Tip should resemble a pencil with the lead broken off.

HOW TO CHECK FOR PROPER WRAPPING

Cut 50 to 100 feet from your new spool of specified wire rope. Braze both ends and run it through a hoist 10 times (no load needed). Check if the strands are separating above or below the hoist. If they DO appear to be opening, then the strands are improperly wrapped and will result in hoist jamming. Return the spool to your supplier.

RIGGING AND REEVING At the job site, rig from the top down. Lower wire rope until you have about 10 feet of rope on the ground (hoist is not yet reeved). Complete the tie point with 3 fist grips (or j-clamps), thimble and shackle (torque fist grips to manufacturer's recommendations). Store the extra wire rope in a coil on the roof. (Note: Adjust wire rope length as you change elevations). Reeve the hoist, form a 360-degree loop in the tail end and retain with a fist grip. Before dereeving the hoist, remove the fist grip.

SAFETY DECALS & INSTRUCTIONS

The following safety/instruction signs shall be on your Sky Climber equipment. All safety related information shipped in the container with the Sky Climber Hoist must be read and complied with at all times.

Nameplate

Part No.: 600-95

Location: Mounted on Electric Box

Operating Instructions

Part No.: 600-96

Location: Mounted on Gear Box

SKY CLIMBER

EXCELLENCE IN ACCESS

220 VAC
60 Hz
1 PHASE
1.5 HP
7.5 AMP
30 MIN. DUTY

COMPACT 1250

MADE IN USA
WORLD WIDE DISTRIBUTION

STONE MOUNTAIN,
GEORGIA
5/16" DIA.
WIRE ROPE
MAX. RATED
LOAD 1250 LBS.

Underwriters Laboratories Certification Decal

Part No. 102-242

Location: Mounted on Electric Box

SCAFFOLDING EQUIPMENT
CLASSIFIED BY
UNDERWRITERS LABORATORIES.

1. AS TO LOAD CAPACITY ONLY
2. AS TO ELECTRICAL FIRE AND SHOCK
HAZARDS ON ELECTRIC WINCHES ONLY. 342J

SKY LOCK ® TYPE III DECALS

SKY LOCK ® TYPE III

OVERSPEED BRAKE 56009839
MAXIMUM LOAD -1250 LBS
USE 5/16" DIAMETER WIRE ROPE ONLY
ACTIVATES ON ROPE WHEN SPEED
EXCEEDS 75 FPM
SKY CLIMBER, INC. - STONE MTN., GA

CAUTION

1. Should the Sky Lock engage due to an overspeed condition, do not release or reset until load has been lowered or tied off on alternative supporting rope. Return Sky Lock to Sky Climber for inspection prior to further use.
2. Sky Lock may also be engaged by:
 - a. Turning manual trip knob counterclockwise.
 - b. Sudden movement of workers on platform or repeated vibration.
 In the event Sky Lock engages for reason other than overspeed, check condition of equipment and wire rope below Sky Lock; if satisfactory, operate hoist in UP direction 3 inches to relieve load on Sky Lock, then turn reset handle clockwise until Sky Lock resets. After resetting, handle must return to vertical position.
3. Inspect and functionally check Sky Lock operation daily when used in normal environments and every 4 hours when used in contaminating environments per instructions contained in manual. Failure to regularly check Sky Lock may result in loss of function with potential injury to user.

**SKY CLIMBER®
COMPACT 1250
OPERATING INSTRUCTIONS**

USE ONLY 5/16" DIAMETER WIRE ROPE
Approved for Sky Climber

1. Sky Lock® OVERSPEED BRAKE
at the start of each work shift by "reset-
ting" wire rope and quickly reeling in the
rope. In the event of a hoist lock-out,
do not attempt to force hoist. Refer to
the SKY LOCK® TYPE III Decal for
operating instructions.

2. FULLY Press the prepared end
of the wire rope through the Sky Lock
hook and into the hoist mechanism
of the hoist. Operate hoist until
the JF direction material is
secure.

3. Check to make sure the
direction of travel is
correct.

4. USE SAFETY - PRINCESS with
no load on the hoist when
operating.

5. INSPECT wire rope, hoist, tool
form and connector: Make at the start
of each work shift to ensure they are in
proper working order.

6. COMPLETELY shut off hoist,
Stop and use RTRN AT CNS
that apply to the situation.

7. If you find a problem
or suspect a problem, power off the
hoist and use the brake to hold
the hoist. Contact your Local Sales
to get toward solution of issue.

8. REFER to case #1517-100-100
MANUAL for more details on
Safety - Princess
RTRN.

MAXIMUM LOAD: 1250 LBS
Model 600-95

STOPS OVERSPEED
ROPE TRAVEL THRU
SKY LOCK IN
ARROW DIRECTION.

SAFETY

Accidents will be prevented if you follow the instructions in this manual. Once the equipment leaves Sky Climber's control, the operator is responsible for its safe use, operation and maintenance.

SAFETY PREVENTS ACCIDENTS

- Know and understand the operation of this equipment.
- All Federal, State, and Local codes and regulations that apply to this equipment and its safe use must be followed.
- Do not alter any Sky Climber Hoists, Sky Locks or Accessories. Use only Sky Climber original parts in your Sky Climber equipment.
- Thoroughly inspect all equipment before use. Do not use any equipment which has any apparent difficulty.
- Wear hard hats at all times when servicing, erecting, disassembling, or using this equipment.
- Secure suspended platform to building face/structure while at work station. Disconnect platform from building face (other than platforms using continuous engagement) before it is moved.
- Provide protection for workers from falling objects both above and below the equipment.
- Keep all persons from beneath suspended equipment.
- Never work alone on a suspended platform and ensure help is available in an emergency.
- Do not overload the equipment or exceed the maximum rated capacity as noted in this Manual.
- Do not wear loose clothing while operating this equipment.

Safety is Important.

Use Common Sense. Don't Take Chances.

Compact 1250 HOIST OPERATOR'S INSTRUCTION MANUAL

Welcome to the ever growing group of Sky Climber Hoist Operators. This Manual will guide you through the features and operation of your Sky Climber Hoist and Sky Lock Secondary Overspeed Brake.

Sky Climber Hoists and Sky Lock Brakes are an integral part of a total Suspended Platform System made up of Rigging, Wire Rope, a Power Supply, the Platform, Fall Arrest/Safety Equipment and Accessories. Understanding the complete system, as well as Hoist operation, will help you in the safe use of a Suspended Platform.

This information is a *guide only* and is not a complete list of safety rules, installation or operations instructions.

Sky Climber Hoists, Sky Locks and Accessories are designed and manufactured to the highest standards in the industry. It is impossible, however, for Sky Climber, Inc. to know, evaluate and advise on every conceivable way our products are used or serviced and of all possible hazardous consequences.

Therefore all operators must satisfy themselves that the procedure they use will not jeopardize their safety, the safety of others or cause product or component damage.

Sky Climber, Inc. reserves the right to continually improve its products. Every effort has been made to make this Manual as accurate as possible at time of publication, however, there may be product changes which are not detailed in this Manual.

OSHA requires all operators of hoist equipment to be trained in its installation and use. Contact Sky Climber for training information.

TABLE OF CONTENTS

HOISTS	
Specifications	3
Characteristics & Operations	4-5
SUSPENDED ACCESS	
Guidelines	6
Top Side Rigging	7
Counterweighted Rigging	7
Tank Top Roller	7
Ring Girder Roller	7
Wire Rope	8
Fall Arrest Equipment	9
Platforms	10
HOIST & SKY LOCK INSTALLATION	
Sky Lock	11
Sky Lock Test	11
Hoist	11-12
Test Hoist Load	12
Test Emergency Stop	12
Test Controlled Descent	12
CHECKLISTS	
Daily	13
Inspection Frequency	13
TROUBLESHOOTING	
Field Conditions	14
MAINTENANCE	15
SAFETY	16
SAFETY DECALS AND INSTRUCTIONS	17

MAINTENANCE

Return Sky Climber Hoists as indicated to Factory Authorized Service Center for maintenance.

- Sky Climber Hoists are lubricated for normal usage and life. If an oil leak is seen, return Hoist to Factory Authorized Service Center.
- Keep rope housing drain holes at bottom of Hoist open.
- **FLUSHING: Keep Hoist and Sky Lock free of contaminants.** Perform the following steps when using equipment in a contaminated environment using gunite, hydroblasting or sandblasting.
 - Lower equipment to ground. Dereeve the Hoist.
 - Hold hose at wire rope entrance, flush Sky Lock with fresh water.
 - Repeat the flushing on the Hoist while running Hoist in the up and down direction until no further contaminants exit from drain holes.
 - Reeve the Hoist and Sky Lock. Continue operation.

FIELD TROUBLESHOOTING

Mechanical portions of Sky Climber Hoists and Sky Lock must not be repaired in the field. Perform only those repairs for which you are qualified and trained. If a problem condition still exists, contact your Sky Climber Representative.

PROBLEM	POSSIBLE CAUSE	CORRECTIVE ACTION
Hoist won't come down	Sky Lock Brake tripped	Overspeed Condition: Get off Platform! Nuisance Tripping: Run System up 1" Reset.
Electric Motor Runs Slow or Hums and won't Lift.	Low source voltage On long drops, too much voltage is lost in electric cord Badly "pitted" points Brake not releasing Defective contactor Capacitor	Use booster transformer or separate drop cords. Use booster transform or run separate electric cord to each unit. Return to Factory Authorized Service Center.
Motor Overheats	Incorrect Voltage	Motors overheat at less than 200V or greater than 240V.
"Popping" Circuit Breaker	Breaker undersized Short in electric cord	Connect to proper size breaker. Replace cord.
Runs in only one direction.	Defective contactor	Return to Factory Authorized Service Center
Motor does nothing.	No Power Thermal protector tripped (motor is usually hot) Emergency stop switch engaged	Restore After 1 hour cooling period. Restart. Disengage
Hoist drifts when stopping in down direction.	Primary brake worn	Return to Factory Authorized Service Center

SKYLOCK

Engages due to overspeed conditions.	Remove Personnel from Platform Lower Platform to Ground or Raise to Roof by means other than Hoist. Contact Sky Climber Representative DO NOT release or reset brake.
--------------------------------------	--

SKY CLIMBER Compact 1250 Air and Electric

SPECIFICATIONS

MODEL	ASCENT SPEED	DESCENT SPEED	WEIGHT (with SkyLock)
220 Single Voltage-Std., 7.5 amp 100 PSI, Air , 70 CFM	33 ft./min.	35 ft./min.	106 lbs.
	30 ft./min.	35 ft./min.	85 lbs.

	SINGLE 220VOLT	Air Powered
Maximum Rate Capacity *	1250 lbs.	1250 lbs.
Wire Rope dia.	5/16 in.	5/16 in.
Dimensions	13.50 in. H	13.50 in. H
	13.50 in. W	13.50 in. W
	17.25 in. L	18.00 in L
RPM	1710 1750	

Detachable Sky Lock Type III Secondary Brake

"No Power" emergency Controlled Descent

Meets or Exceeds OSHA requirements, U.L. Classified.

* Maximum Rated Capacity (MRC) is total load supported by Hoist. It includes the combined weights of the stirrup, platform, work cage, bosun chair, personnel, work tools/materials, operating accessories, power cord, wire rope, and hoists.

CHARACTERISTICS & OPERATIONS

Compact 1250 ELECTRIC SINGLE VOLTAGE and AIR HOISTS WITH SKY LOCK TYPE III

Compact 1250 ELECTRIC SINGLE VOLTAGE HOIST WITH SKY LOCK TYPE III

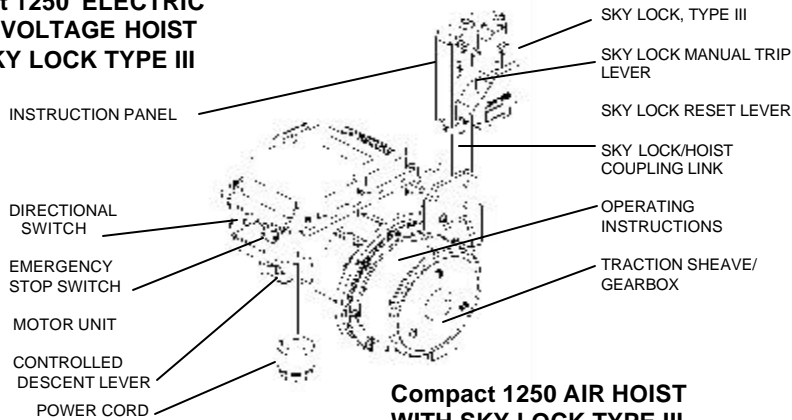

Compact 1250 AIR HOIST WITH SKY LOCK TYPE III

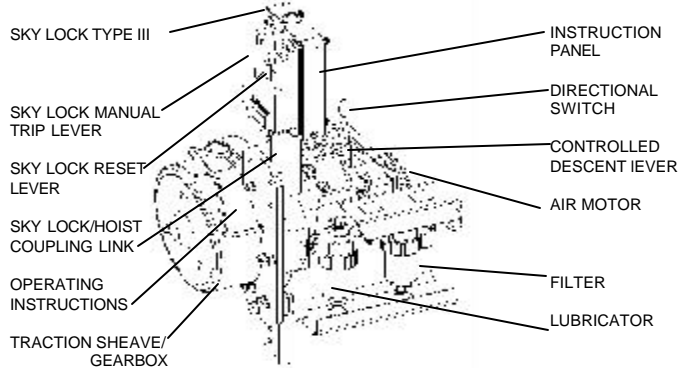

HOIST



NOTICE

Select proper source voltage (220V) to match hoist voltage
BEFORE connecting power.

Directional Switch: Switch activates and operates the Hoist. Select UP direction to move unit up. Select DOWN direction to move unit down. Release switch to cut power to motor and set primary brake.

Emergency Stop Switch: Push to stop power to Hoist and set primary brake. Turn *clockwise* to reset.

Controlled Descent Lever: *Do not use for normal lowering operations.* For non-powered descent, controlled descent lever manually releases and re-engages primary Hoist brake. Disconnect power at pigtail connection **BEFORE** using the Controlled Descent Lever.

CHECKLISTS

DAILY OR BEFORE START OF EACH SHIFT

DO NOT use Sky Climber Hoists, Sky Locks or equipment which is damaged or worn beyond normal tolerances.

1. Instructions are kept with the unit at all times.
Additional copies are available. Contact Sky Climber.
2. All Warning / Rating Labels are in place, legible and have been read.
3. Hoist Drain Holes on Bottom Are Open. Fasteners checked.
4. Suspended Platform Hoist is connected to proper power source.
5. Minimum of 3 J-clamps are used and are tight.
6. Cornice hook, parapet clamps or outriggers and similar rigging are secured and tied back. Chocks or similar devices are securely in place. Tie backs are tight and straight back.
7. Counterweights are nonflowable type, secure, and right amount.
8. Roof rigging load is spread using 3/4 in. plywood. Hard wood used for Load Spreader with Parapet.
9. Wire rope inspected and is not kinked, bird caged or otherwise damaged.
10. The wire rope bitter end is looped and secured with a J-clamp.
11. Sky Lock, Hoist Load, Controlled Descent, Emergency Stop Tests performed and acceptable.

INSPECTION FREQUENCY AND MAINTENANCE



WARNING

Failure to comply with Periodic Inspection and Factory Authorized Service Maintenance may result in a malfunction and in serious personal injury, property damage or death.

Field Inspection

Inspection must be performed by a designated qualified person or operator.

Inspection Frequency

Inspect **ALL** equipment as follows:

- When system is reeved.
- At start of each work shift.
- At least every four hours in abrasive, caustic or adhesive conditions.
- At least every two hours in freezing conditions.

Factory Inspection, Maintenance and Testing

Return Sky Climber Hoists and Sky Lock Brakes to a Factory Authorized Service Center for inspection, maintenance and testing as follows:

- Every 12 months in noncontaminated or freezing environments.
- Every 6 months in contaminated or freezing environments.
- After every job for Gunite, Hydroblasting or Sandblasting.

5. Assemble Sky Lock to Hoist with Coupling Link.

Coupling Link must provide clearance for straight passage of wire rope.

- Remove Coupling Link from storage box.
- Line up Coupling Link with hole in top of Hoist.
- Attach with shoulder bolt. Tighten nut securely.
- Slide Sky Lock up 1 inch then turn Sky Lock Reset Lever *clockwise* to open jaws letting Sky Lock slide down wire rope.
- Line up hole in Sky Lock with top of Coupling Link.
- Attach shoulder bolt. Tighten nut securely.

6. Secure Wire Rope End.

- Loop wire rope bitter end and secure with a J-Clamp. Keep wire rope bitter end off ground to keep it clean and allow rotation.

7. Test Hoist Load.



WARNING

Serious injury or property damage may result from falling objects during Hoist Load Test. Be alert and prepared to quickly move from likely impact zone.

- Place load equal to weight of workers & tools/materials on one end of Platform. Have co-worker check rigging for slippage/ malfunction during test.
- Inspect all rigging/platform connections. Tighten or adjust as needed.
- Select Hoist Directional Switch UP direction to raise Platform **6 inches** off surface.
- Turn Manual Trip Lever *counterclockwise* to set Sky Lock Brake.
- Select Hoist Directional Switch DOWN direction. **System should not descend.** Wire rope will loop out between top of Hoist and bottom of Sky Lock.
- Select Hoist Directional Switch UP direction to take up the loop and raise Platform **1 inch** to relieve load from Sky Lock jaws.
- Turn Sky Lock Reset Handle *clockwise* to reset Sky Lock.
- Repeat procedure twice.
- Repeat same Hoist load test procedure at other end of Platform.
- If Hoist or Sky Lock fails test, return failed unit to Factory Authorized Service Center.

8. Test Emergency Stop Button.

- Select Hoist Directional Switch UP direction to raise Platform **6 inches**. While ascending, press Emergency Stop Button. Power should stop to Hoist and primary brake should engage.
- Turn Emergency Stop Button Switch *clockwise* to reset.
- Repeat test.
- If emergency stop fails, return Hoist to Factory Authorized Service Center.

9. Test Controlled Descent System.

Partial Hoist brake release may result in overheating and premature wear.

- Raise Suspended Equipment **2 feet** off ground.
- Use Controlled Descent Lever to manually release primary Hoist brake.
- For nonpowered descent, pull Controlled Lowering Lever as far as it will go toward end of motor.
- The Hoist should lower at less than 40 feet per minute.

Do Not Use Any Equipment that has failed testing.

ELECTRICAL



WARNING *Do Not use an electric hoist in an explosive environment.*

*Secure cord to Platform so cord weight is on Platform and **NOT** on connection. At end of work shift, disconnect power cord from main outlet. Protect power cords from rain and water at all times. Ground connector of building receptacle must be grounded.*

- For 220 volt applications, use one cord in combination with a yoke to the Hoists.
- Use a yoke off Platform line with two lengths of 10-3 SOW electric cord.
- Normally a 250 ft., 600 volt, 10-3 SOW electric cord is used.
- Use a booster transformer when low voltage is encountered.

AIR

Secure hose to Platform so weight of hose is not on unit. Install two shut off valves - one at air supply source and one on Platform.

- Use a yoke off Platform line with two equal length 3/4 in. hoses.
- Hose Inner Diameter (for 100 PSI and 70 CFM / Hoist).

Hose Inner Diameter	3/4"	1"	1 1/4"
One Unit	400 ft.	1000 ft.	1000+
Two Units - Yoked	100 ft.	300 ft.	1000+

Filtering and Lubrication

Do not connect to air systems which use synthetic fire-resistant lubricants, especially phosphate ester types, in the air compressor,

- An air filter and a lubricator are mounted in the input line ahead of the motor. Clean filter elements periodically.
- To service lubricator, remove oil fill plug, fill to visible rim of bowl with SAE No. 10 petroleum based hydraulic or spindle oil. Do not use oils with adhesive or tacky additives. Replace plug.
- Adjust oil flow to about 6 drops per minute. Turn slotted screw in top of lubricator clockwise for leaner mix or counterclockwise for richer.

SKYLOCK SECONDARY BRAKE



WARNING

A Sky Lock Secondary Overspeed Brake safety device must be used at all times with each Sky Climber Hoist.

Failure to do so is in violation of OSHA and may result in serious injury or death.

The Sky Lock senses the speed of the wire rope traveling through it. If there is sudden acceleration due to a falling condition or if the factory preset trip speed is exceeded, the Sky Lock jaws clamp onto the wire rope, arrest any descent and support the descending load. The wire rope releases only **AFTER** the Sky Lock Brake load is relieved.

Sky Lock Manual Trip Lever: Turn lever counterclockwise to clamp the Sky Lock jaws onto the wire rope.

Sky Lock Reset Lever: First use Hoist Directional Switch "UP" to move Hoist in up direction 1 inch to relieve load from Sky Lock Jaws. Turn Sky Lock Reset Lever **CLOCKWISE** to reset. *If you don't go up before resetting, the Sky Lock jaws will not open and the Sky Lock Reset Lever pin will shear. This will render the Sky Lock as useless and require factory authorized repair.*

SUSPENDED ACCESS INSTALLATION

GUIDELINES

Safety is of utmost importance when installing and using Suspended Platform equipment.

This section covers general guidelines. Follow your Manufacturer's Instructions for proper equipment assembly. Follow all applicable Federal, State and Local rules and regulations.

- Test your System *before* going aloft.
- Continue to check and be sure your system remains safe throughout the entire use on the job.
- Make certain there are no obstructions to the vertical Platform travel.

TOPSIDERIGGING



Rigging is the responsibility of the user. Do not attempt to rig a job unless you are qualified. Failure of rigging will result in serious injury or death.

- All rigging including cornice hooks, parapet clamps and outrigger beams must be tied back to a structural member with wire rope that is equal, or greater in ultimate strength than suspension line.
- Tie back must be tied tight to a substantial point that supports at least 4 times the rated Hoist load. Tie-back to vent pipes is not acceptable. Tie backs must be straight back and each to a separate anchor point.
- Use parapet clamps and cornice hooks **only** on steel reinforced concrete structures. Do not use on nonreinforced brick, concrete block or stone parapets because these may fail.
 - Consult a professional engineer or building owner to verify parapet construction and strength.
- Use 3/4 in. plywood under roof rigging to spread load on roof. If parapet is used for support, use hard wood for load spread.
- Rolling Roof Rig chocks, jacks or similar devices must be securely in place to prevent any lateral movement.

Counterweighted Rigging

- Outrigger beams require counterweights.
- Counterweights must be secured to the outrigger beam and of a nonflowable material.
- To calculate the needed counterweights, use the following formula:

$$CW = \frac{4 \times R \times L}{A}$$

- CW = Counterweight (in lbs.) per outrigger beam.
4 = 4:1 Safety Factor (required by OSHA).
R = Distance from Front Support center line to Hanging Load (in feet).
L = Rated Working Load (RWL) of Hoist.
A = Overall distance from front support to CW center line (in feet).

HOIST & SKY LOCK INSTALLATION

ASSEMBLE SUSPENDED PLATFORM

1. Follow Manufacturer's Instruction.
2. If used, install an electric yoke on the platform (wrapped around center guardrails) to provide power to each Hoist.
3. Secure source power line(s) to Suspended Platform by strain relief(s) or other load bearing device. Plug the power line into yoke, if used.
4. Allow sufficient power line length to permit free Platform travel without undue strain to the power line and platform.

INSTALL SKY LOCK

1. **Insert end of hanging wire rope through Sky Lock.**
 - Move Sky Lock up rope to a location above Hoist attachment point.
2. **Test Sky Lock.**
 - Support Sky Lock vertically. Drop Sky Lock down the wire rope. Brake should lock onto rope within 3 inches or less.
 - Slide Sky Lock up wire rope 1 inch.
 - Turn Reset Handle clockwise to reset Sky Lock.
 - Repeat procedure twice. Leave Sky Lock on line for Hoist reeving.
 - *Sky Lock must lock onto rope within 3 inches or less. If it does not, Sky Lock MUST be replaced.*
3. **After test proceed with Hoist Installation.**

INSTALL HOIST

1. **Place Hoist next to Suspended Platform Stirrup.**
2. **Connect Power.**
3. **Thread Wire Rope Through Hoist.**

Keep hands clear of pinch point where wire rope enters Hoist.

 - Feed brazed and pointed end of wire rope with Sky Lock Brake already hanging on the rope, into Hoist entrance guide until rope stops.
 - To start self-reeving: Move Directional Switch in UP direction.
 - Wire rope must be free to travel without interference.
 - Exit guide must be clear. Wire rope must run freely **AWAY** from Hoist
 - Guide Hoist as it climbs up to the Stirrup level.
4. **Attach Hoist to Suspended Platform Stirrup.**
 - Insert Hoist stirrup strap into platform stirrup recess.
 - Use either Grade 5 nuts/bolts or shoulder bolts and nuts provided by manufacturer. Tighten nuts securely.

PLATFORMS

- Follow the Platform load specification.
- Check stirrup bolts daily for soundness and tightness.
- Use toeboards, handrails and midrails on all open sides.
- Acids can destroy aluminum Platforms. Replace Platform immediately if exposed to acids or corrosive materials.
- Operate platform in level position only.
- Work from deck of platform only. Do not stand on guardrails, toeboards, platform/work cage supported objects or lean out from ends of platform. Do not use ladders etc. to get at higher elevations.
- Do not bridge from one platform to another, nor to any structure or other equipment.
- Do not horizontally transfer a work platform while it is suspended in the air. Perform all transfer operations ONLY with the Platform resting on a safe surface.
- Bosun chairs should only carry the operator. Do not hang loads from the seat or attach any device or support to seat or seat back.

WELDING

- Use the following precautions when welding to prevent the possibility of electric shock to personnel and /or the possibly of welding current passing through the wire rope.
- Attach each wire rope to its suspension point with a suitable insulated thimble. Insulate extra rope stored on the roof to prevent grounding, or terminate the suspension rope at the insulated thimble.
- Cover the supporting wire rope with insulating material above and below the Sky Climber® hoist. Use a length of split rubber tube taped in place around the cable as follows:
 - a. Extend above the Sky Lock brake for 4 to 5 feet (more if required by local codes).
 - b. Extend below the Sky Climber® Hoist, far enough to insulate the tail line from the platform. Guide and/or retain the portion of the tail line below the platform so that it does not become grounded.
- Cover each Sky Climber Hoist, Sky Lock brake and wire winder with protective covers made from insulating material.
- Connect a grounding conductor from the platform to the work piece. The size of this conductor must be equal to or greater than the size of the stinger lead.

NOTE: This must be a secondary conductor and must not be in series with the primary conductor between the welder and work piece.

TYPICAL TOP SIDE RIGGING

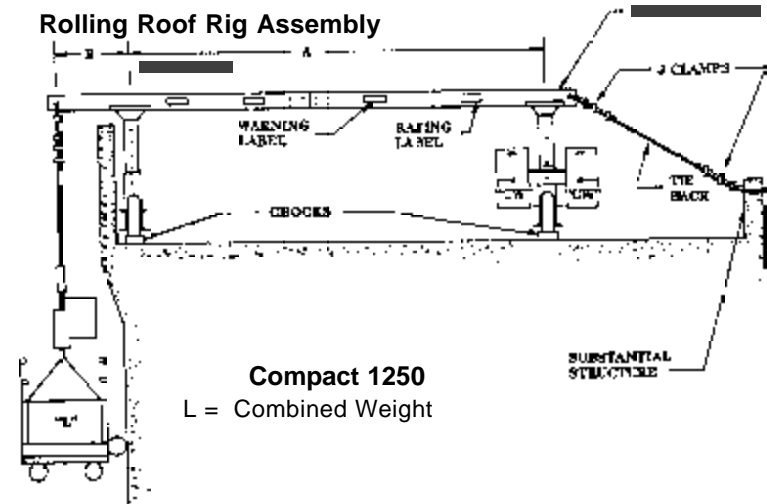

Non-Counterweighted Rigging

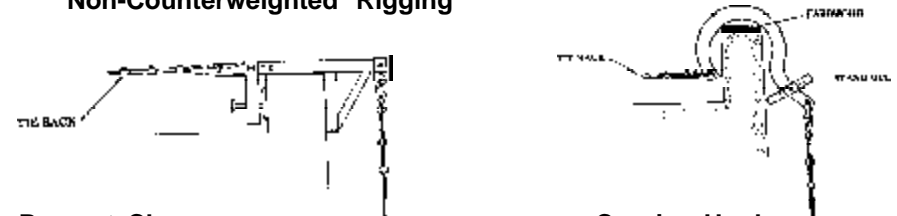

Parapet Clamp

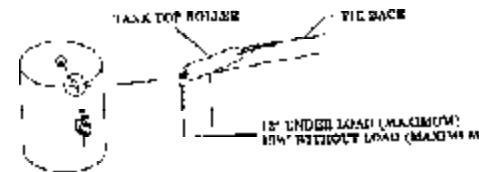

Tank Top Roller

Tank Top Roller

- Tank top rollers provide a rigging method for access to petroleum or storage tanks.
- Connect Lifelines to separate attachment point capable of a 5000# load.

Ring Girder Roller

- Ring Girder Rollers are used where a steel ring girder is located around the storage tank perimeter.
- Connect Lifelines to separate attachment point capable of a 5000# load.

WIRE ROPE



WARNING

Wire rope is an expendable item. It begins to wear when it is put into use. Do not use kinked, birdcaged or excessively worn or damaged wire rope. Such use may result in injury or death to yourself or others.

Wire Rope Handling and Storage

- Always wear gloves to protect hands when working with wire rope.
- Store wire rope in a coil or on a spool. Protect rope from physical abuse, inclement weather and corrosive materials.
- Do not drop wire rope from any heights.
- Uncoil wire rope carefully to avoid kinking or inducing a twist.
 - Do not uncoil by tossing coil over the edge of structure.
- Avoid dragging wire rope in dirt or around objects that could scrape, crush, bend or damage it.
- Galvanized wire rope specified by Sky Climber, Inc. is lubricated at the factory and under normal conditions does not require further lubrication.

Wire Rope Preparation

- Always use 5/16 in. wire rope of the proper length and construction.
 - 5/16" 4x26S, PFC, G, XIP, RL
 - 5/16" dia., 6x19 IWRC, improved plow steel, drawn galvanized.
- Braze both ends a maximum 1/2 in. long. Air cool then grind the tip to a blunted point.

Wire Rope Rigging

Always use correct size and type of rope clamps. Wire rope will slip through oversize clamps. Undersize clamps will damage wire rope.



WARNING

After reeving Hoist, loop the wire rope bitter end and secure with a J-clamp. Failure to do so on a too short wire rope may result in personal injury or death. Remove J-clamp before dereeving Hoist.

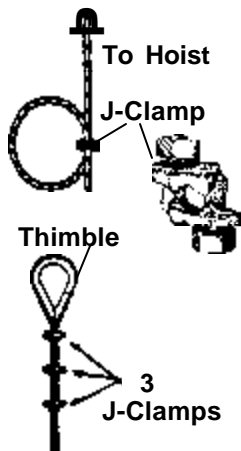

- Use only 5/16 in. J-type wire rope clamps with a minimum of three clamps spaced from 2 to 4 inches apart.
DO NOT USE U-type clamps which can crush wires and reduce wire rope strength.
- Torque J-clamps to 30 ft.-lb. at first loading.
Check for tightness at start of each work shift.
CLAMPS DO LOOSEN WITH USE!
- After all J clamps are placed, test for 125% ProofLoad.
Retighten clamps to specifications.
- Use a 5/16 in. thimble and 5/8 in. screw pinshackle.
- Use insulated thimbles when welding from Platform.

- Wire rope must support 6:1 safety factor.
 - A properly made 5/16 in. wire rope will have a minimum breaking strength of 9,400 lbs.
- Rig from top of structure. Allow 10 extra feet of wire rope to reeve Hoist. Store extra wire rope on roof neatly coiled, tied, and protected from weather **OR** coil wire rope under Platform just off ground level to avoid damage and allow wire rope rotation.
- Wire rope must be rigged to remain vertical with suspension points directly above the Hoist entry guide or lead-in device.

Wire Rope Replacement

- Wire rope is critical to safe and trouble free operation.
- Replacement rope shall be to Sky Climber's specifications. Use of wire rope obtained from sources other than those specified by Sky Climber could result in serious personal injury, property damage and/or equipment breakdown.

Four Wire System

Four wire systems can be used when it is necessary to protect workers having platforms or canopies overhead and as part of the system. Contact your Sky Climber Representative when Four Wire Systems are needed.

FALL ARREST EQUIPMENT

OSHA requires an independent life line for each person going aloft. A safety harness must be worn by each worker and attached by a lanyard and rope grab to an independent life line while worker is on Platform.

Life Lines

- Only one person may be attached to a life line.
- The life line must be:
 - Sized for and compatible with the rope grab (eg. 5/8 in. line for a 5/8 in. rope grab).
 - Certified minimum breaking strength of 5,000 lbs.
 - Seized or whipped at the ends.
 - Tied off to a separate attachment point different from the wire rope attachment point capable of supporting 5,000 lbs.
- Life line must not be in contact with rough or sharp edges.
- Life line must extend to the ground or next lower safe surface.

Rope Grab

Inspect all parts of the rope grab prior to each use. Perform a documented rope grab inspection at least twice a year.

- The rope grab should always be mounted on the life line as far above the operator as possible.

Body Harnesses

Harnesses must comply with the latest edition of ANSI A10.14

- Position a body harness D-ring in the center of the back rib cage. Follow the safety equipment manufacturer's instructions.

Lanyards

Lanyards must meet or exceed OSHA standards.

- Lanyards must be 4 feet long or less with double snap locks.
- Minimum tensile strength is 5,000 lbs.